

MB 140



construction materials: PP - PVDF



PVDF

Intake connection	G 2" m	
Delivery connections	G 1 1/2" m	
Max. flow rate*	40 m ³ /h	
Max. head*	21 m	
Seal	TL - TS	
Motor power	3 kW - 4 HP	
Motor	IP55 - F Class - 2-pole - 230/400 V 50 Hz - three-phase - 2900 RPM	
Diameter of passing solids	12 mm	
Max. viscosity	500 cps	
Net weight	PP	29 Kg
	PVDF	30 Kg
		60°C Max. temp.
		90°C Max. temp.

* The curves and performance values refer to pumps spare delivery outlet and water at 20°C.

TECHNICAL DATA

PERFORMANCE

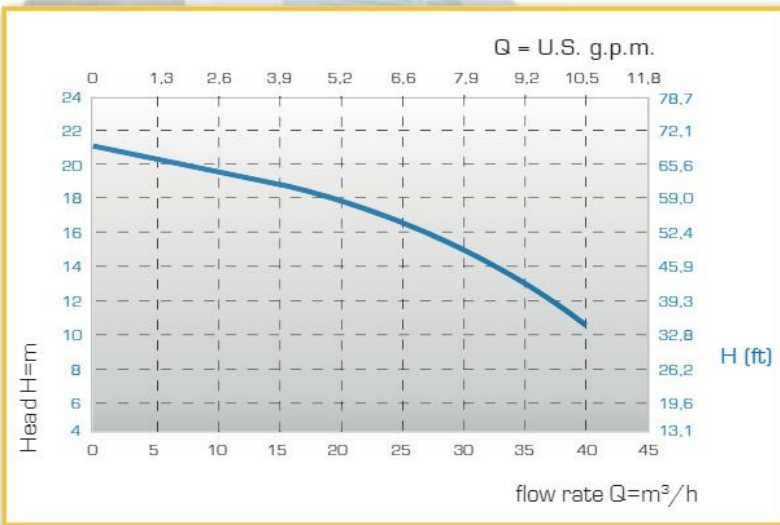

PP

DIMENSIONS

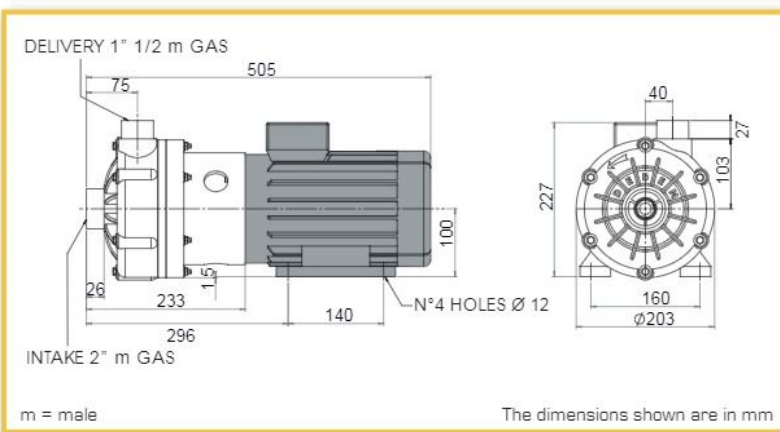

All the values shown are approximate and not binding