



MB 150

construction materials: PP - PVDF

Intake connection	G 2" 1/2 f	
Delivery connections	G 2" m	
Max. flow rate*	42 m ³ /h	
Max. head*	25 m	
Seal	TL - TS	
Motor power	4 kW - 5.5 HP	
Motor	IP55 - F Class - 2-pole - 230/400 V 50 Hz - three-phase - 2900 RPM	
Diameter of passing solids	2 mm	
Max. viscosity	500 cps	
Net weight	PP	8.5 Kg
	PVDF	9.5 Kg
		60°C Max. temp.
		95°C Max. temp.

* The curves and performance values refer to pumps spare delivery outlet and water at 20°C.



PP

TECHNICAL DATA



PVDF

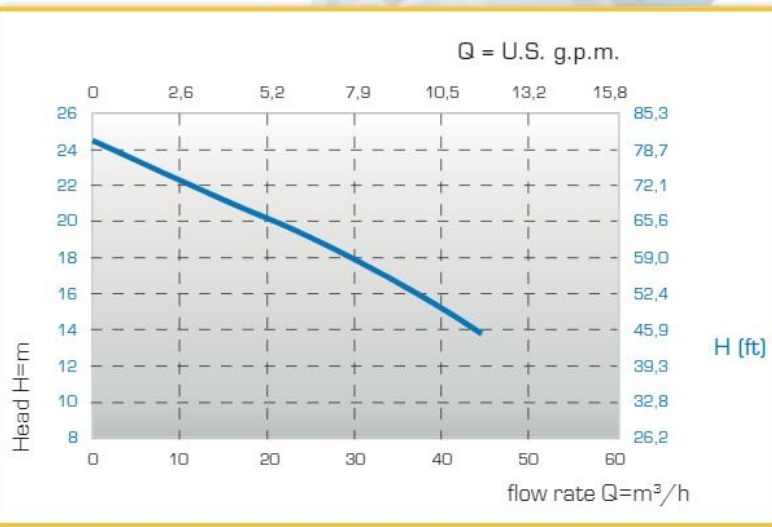

PERFORMANCE

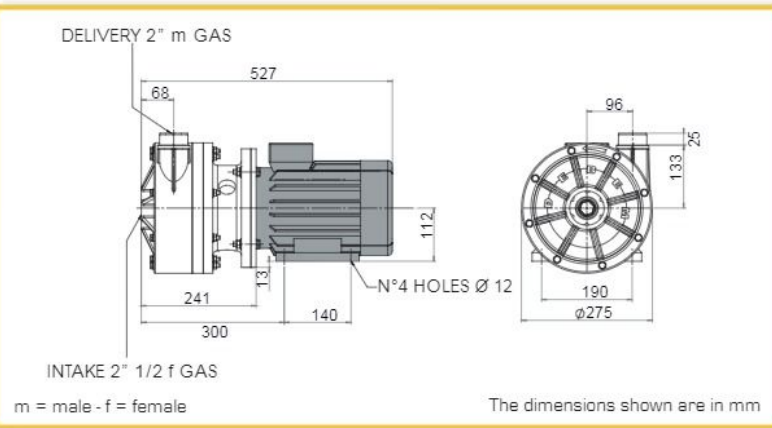

DIMENSIONS

All the values shown are approximate and not binding