

# MB 100



construction materials: PP - PVDF



PVDF

Intake connection	G 1" 1/2 f	
Delivery connections	G 1" m	
Max. flow rate*	9 m <sup>3</sup> /h	
Max. head*	10.5 m	
Seal	TL - TS	
Motor power	0.55 kW - 0.75 HP	
Motor	IP55 - F Class - 2-pole - 230/400 V 50 Hz - three-phase - 2900 RPM	
Diameter of passing solids	7 mm	
Max. viscosity	500 cps	
Net weight	PP	8.5 Kg
	PVDF	9.5 Kg
		60°C Max. temp.
		90°C Max. temp.

\* The curves and performance values refer to pumps spare delivery outlet and water at 20°C.

## TECHNICAL DATA

### PERFORMANCE

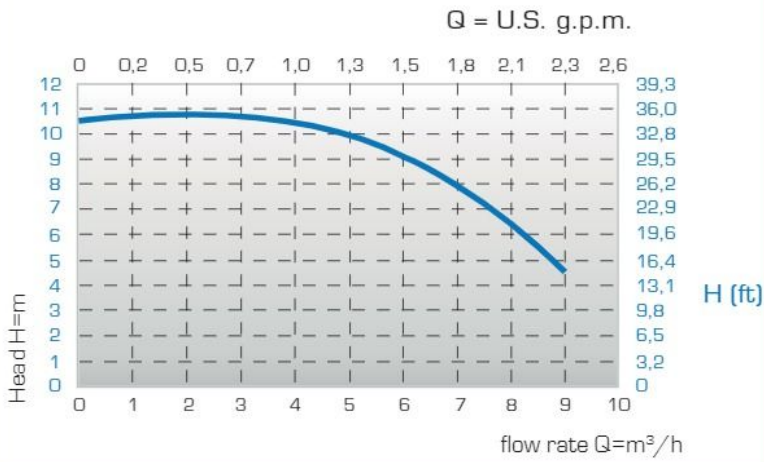

PP

### DIMENSIONS

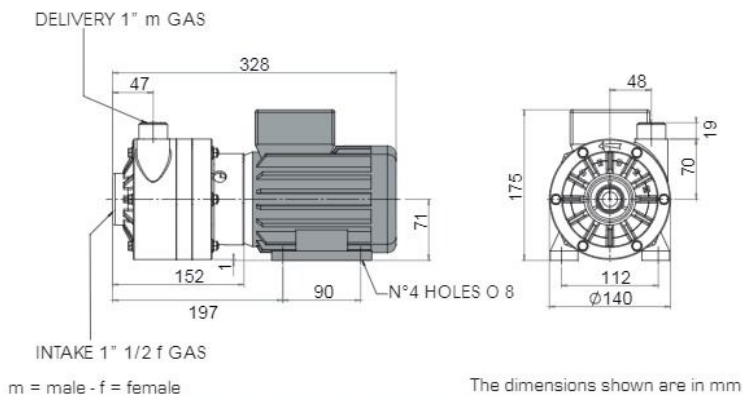

All the values shown are approximate and not binding