



MB 110

construction materials: PP - PVDF

Intake connection	G 2" m		
Delivery connections	G 1" 1/2 m		
Max. flow rate*	20 m ³ /h		
Max. head*	15 m		
Seal	TL - TS		
Motor power	1.1 kW - 1.5 HP		
Motor	IP55 - F Class - 2-pole - 230/400 V 50 Hz - three-phase - 2900 RPM		
Diameter of passing solids	2 mm		
Max. viscosity	500 cps		
Net weight	PP	16 Kg	60°C Max. temp.
	PVDF	17 Kg	90°C Max. temp.

*The curves and performance values refer to pumps spare delivery outlet and water at 20°C.



PP

TECHNICAL DATA



PVDF

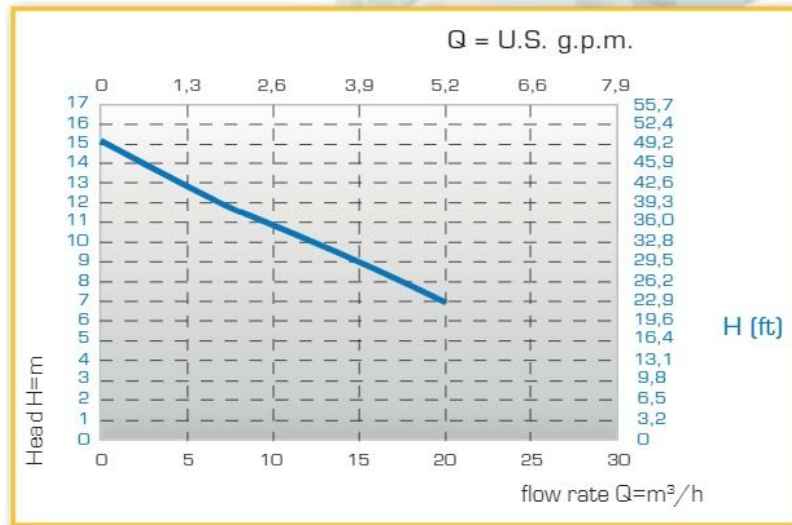

PERFORMANCE

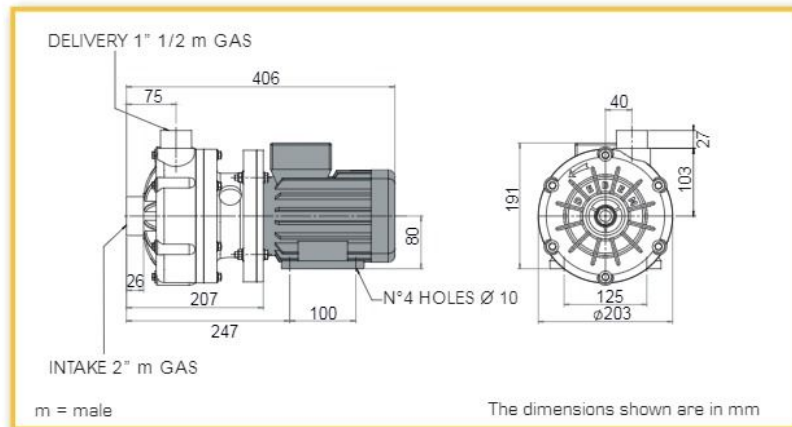

DIMENSIONS

All the values shown are approximate and not binding