



MB 130

construction materials: PP - PVDF

Intake connection	G 2" m	
Delivery connections	G 1 1/2" m	
Max. flow rate*	30 m ³ /h	
Max. head*	20 m	
Seal	TL - TS	
Motor power	2.2 kW - 3 HP	
Motor	IP55 - F Class - 2-pole - 230/400 V 50 Hz - three-phase - 2900 RPM	
Diameter of passing solids	6 mm	
Max. viscosity	500 cps	
Net weight	PP	22.5 Kg
	PVDF	23.5 Kg
		60°C Max. temp.
		90°C Max. temp.

* The curves and performance values refer to pumps spare delivery outlet and water at 20°C.



PVDF

TECHNICAL DATA



PVDF

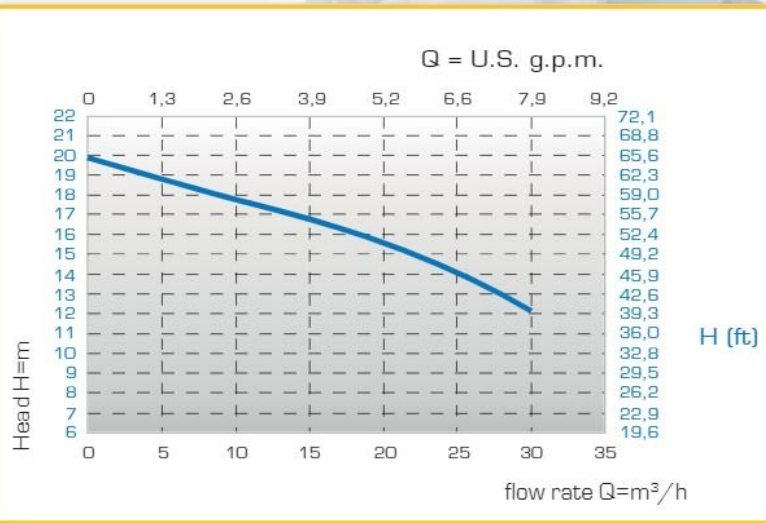

PERFORMANCE

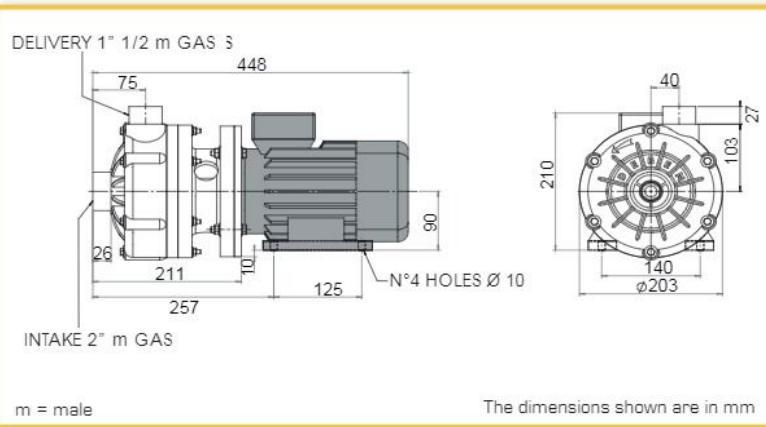

DIMENSIONS

All the values shown are approximate and not binding