

MB 80

construction materials: PP - PVDF

Intake connection	G 1" 1/2 f		
Delivery connections	G 1" m		
Max. flow rate*	6 m ³ /h		
Max. head*	7,2 m		
Seal	TL - TS		
Motor power	0,37 kW - 0,5 HP		
Motor	IP55 - F Class - 2-pole - 230/400 V 50 Hz - three-phase - 2900 RPM		
Diameter of passing solids	5 mm		
Max. viscosity	500 cps		
Net weight	PP	8.5 Kg	60°C Max. temp.
	PVDF	9.5 Kg	90°C Max. temp.

* The curves and performance values refer to pumps spare delivery outlet and water at 20°C.



PVDF

TECHNICAL DATA



PP

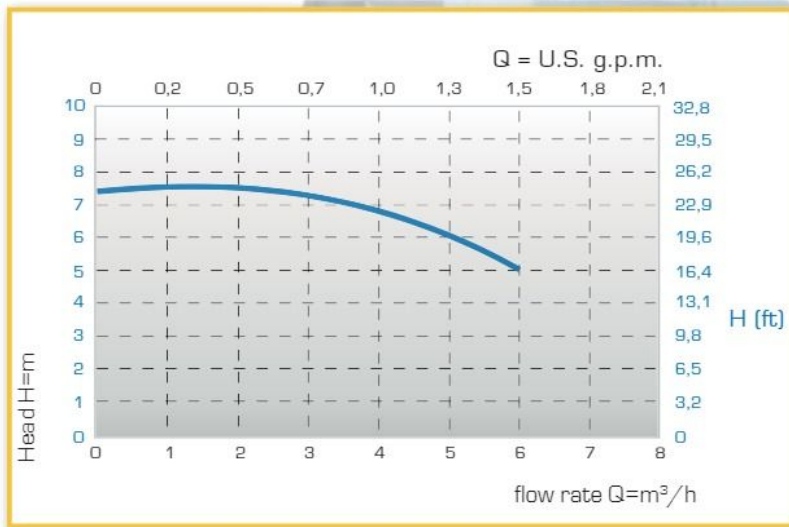

PERFORMANCE

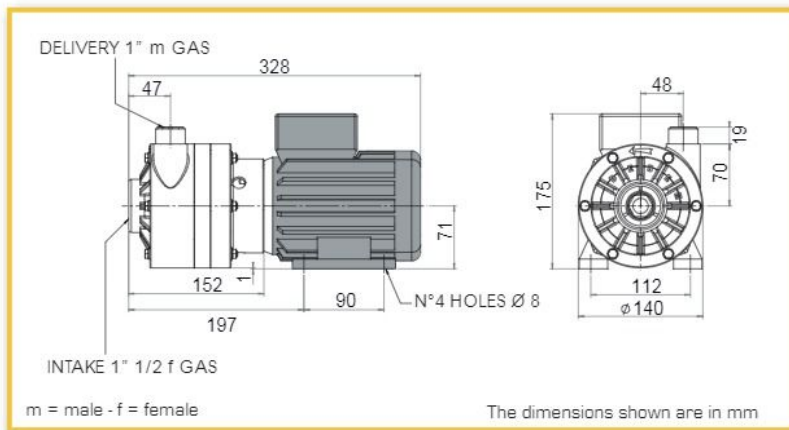

DIMENSIONS

All the values shown are approximate and not binding