

SALES & ENGINEERING DATA

650492-X43-B EXTRUSION PUMP

RATIO SERIES:	23:1
FLUID PSI RANGE:	0 - 3690

RELEASED: 11-6-98
REVISED: 5-27-10
(REV. 02) S-1062

DIMENSIONAL DATA

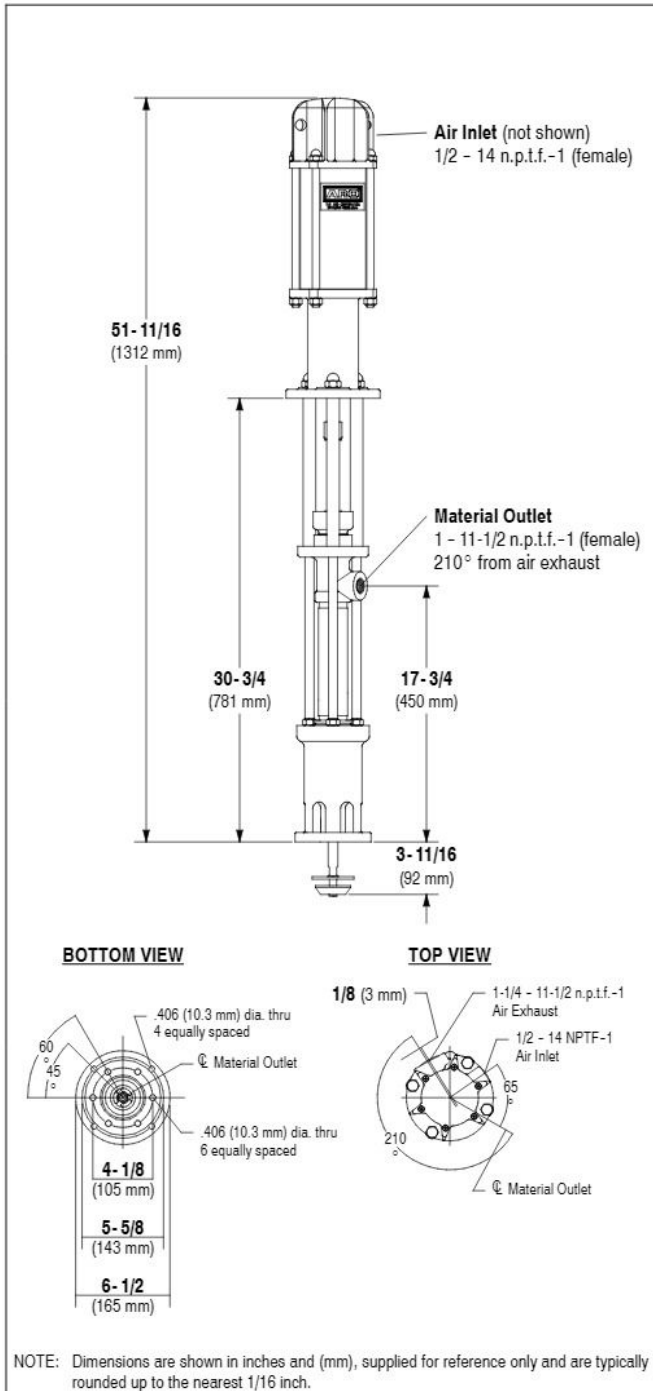

SPECIFICATIONS

CONSTRUCTION

Model Series (refer to option chart)	650492-X43-B
Pump Type	Air Operated, Extrusion, Double Acting Pump
Ratio	23:1
Air Motor	65465-B
Motor Repair Kit	61268
Motor Diameter	4-1/4" (107.9 mm)
Stroke	6" (152.4 mm)
Air Inlet	1/2 - 14 n.p.t.f.-1 (female)
Air Exhaust	1-1/4 - 11-1/2 n.p.t.f.-1 (female)
Lower Pump End Series	66266-X43-B
Lower Pump Repair Kit	637074-X43-B
Packing Options:	

3 - Glass Filled PTFE
C - UHMW-PE
G - UHMW-PE / Leather staggered
P - UHMW-PE / PTFE staggered upper • UHMW-PE lower
R - PTFE / UHMW-PE staggered upper • PTFE lower

Material Inlet	immersed
Material Outlet	1 - 11-1/2 n.p.t.f. - 1 (female)

MATERIALS OF CONSTRUCTION

Outlet Body	Ductile Iron, E Nickel plated
Cylinder	Carbon Steel, Nickel plated
Plunger	17-4 Stainless Steel, Chrome plated
Upper Check	440 Stainless Steel
Upper Seat	440 Stainless Steel
Lower Check	440 Stainless Steel
Lower Seat	440 Stainless Steel
Inlet Body	Ductile Iron, Nickel plated
Weight	63.7 lbs (28.9 kgs)

PERFORMANCE

Air Inlet Pressure Range	0 - 150 p.s.i. (0 - 10.3 bar)
Fluid Pressure Range	0 - 3690 p.s.i. (0 - 254.5 bar)
Max. Rec'd Cycles / Minute	60
Displacement In ³ Per Cycle	6.97
Volume / Cycle	3.9 oz. (114.2 ml)
Cycles Per Gallon	33.1
Flow @ 60 Cycles / Minute	1.8 g.p.m. (6.9 l.p.m.)
Noise Level @ 60 p.s.i. - 40 c.p.m.	80.0 db(A)Ⓢ

Ⓢ Tested with 91790 Muffler installed. The pump sound pressure level has been updated to an Equivalent Continuous Sound Level (L_{Aeq}) to meet the intent of ANSI S1. 13-1971, CAGI-PNEUROPS 5.1 using four microphone locations.

ACCESSORIES:

66101 Wall Mount Bracket
67187-1 Mounting Post
91790 Silencer

airpumping.co.uk

est. 1979

Unit 16, Upminster Trading Park, Warley St., Upminster, Essex, RM14 3PJ, ENGLAND

ARO

IR Ingersoll Rand
Industrial Technologies

PERFORMANCE CURVES

