

customised
precision state
highest
quality

C new

100 Bar

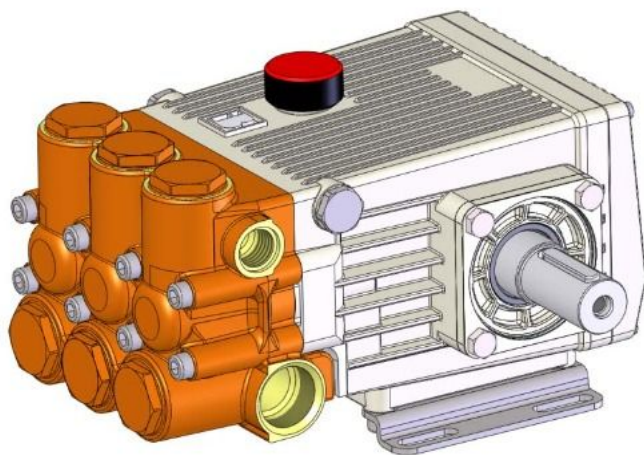

DATA - DATI TECNICI		C 100 Bar	
IN	DIAMETER	Ø	G. 1"1/4
	PRESS.	Max	6 Bar 87 PSI
		Min	-0.1 Bar -1,5 PSI
TEMP.	Max	74° C 165° F	
OUT	DIAMETER	Ø	G. 3/4"
SHAFT		Ø	35 mm
PESO WEIGHT		KG lbs	25 55
OIL		SAE 80W 90	1.69 litri 0.4 U.S.G.

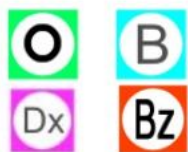

OPT.

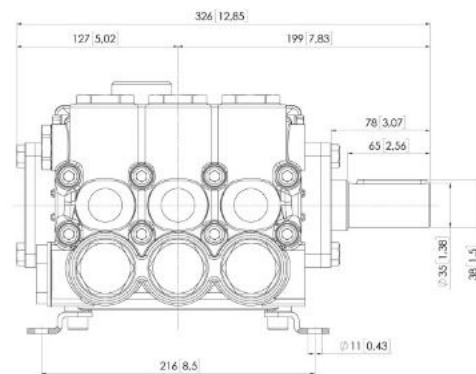
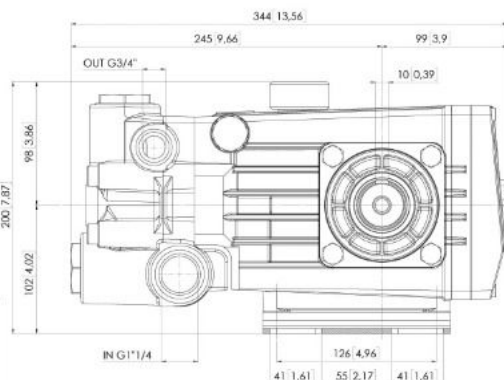

CARATTERISTICHE – FEATURES

PERFORMANCE CHART

MODELLO CODICE	MODEL CODE	Max l/min GPM	PRESS.		RPM 950				RPM 1200				RPM 1450				PIST. PLUNG. Dia . mm	CORSA STROKE mm
			BAR	PSI	l/min	GPM	kW	HP	l/min	GPM	kW	HP	l/min	GPM	kW	HP		
C 8010 53.5000.97.3	80	21,1	80	1160	55	14,6	8,7	11,6	68	18,0	10,7	14,4	80	21,1	12,6	16,8	30	28
			90	1305	55	14,5	9,7	13,0	68	17,9	12,0	16,1	80	21,0	14,1	18,9		
			100	1450	55	14,4	10,7	14,4	67	17,8	13,3	17,8	79	20,9	15,5	20,8		
C 1010 53.5001.97.3	96	25,4	80	1160	67	17,7	10,5	14,1	83	21,9	13,0	17,4	97	25,7	15,3	20,5	30	34
			90	1305	67	17,6	11,8	15,8	82	21,8	14,6	19,5	97	25,5	17,1	22,9		
			100	1450	66	17,5	13,0	17,5	82	21,6	16,1	21,6	96	25,4	18,9	25,3		
C1210 53.5002.97.3	109	28,9	80	1160	76	20,2	12,0	16,1	94	24,9	14,8	19,8	110	29,2	17,4	23,3	32	34
			90	1305	76	20,1	13,4	18,0	94	24,8	16,6	22,2	110	29,0	19,4	26,1		
			100	1450	76	20,0	14,8	19,9	93	24,6	18,3	24,6	109	28,9	21,5	28,8		