

CARATTERISTICHE - SPECIFICATIONS

IN	DIAMETER	∅	G. 1"
	PRESS.	Min.	-0.1 bar -1.5 PSI
		Max.	6 Bar 87 PSI
TEMP.	Max.	60° C. 140° F.	
OUT	DIAMETER	∅	G. 1/2
SHAFT		∅	40 mm
OIL	SAE 75W90		4 litri 1.05 U.S.G.
PESO WEIGHT		Kg / lbs	87.8 / 193

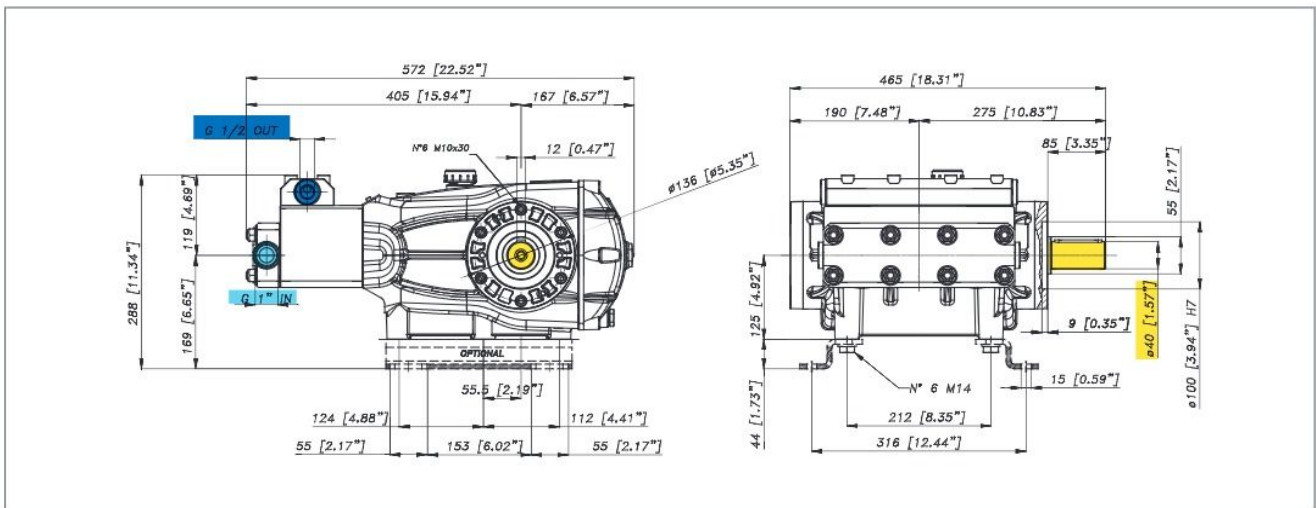

KIT PIEDINI cod. 74.9802.97.3 (optional)
 MOUNTING RAILS KIT p/n 74.9802.97.3 (optional)
 KIT SUPPORTS réf. 74.9802.97.3 (option)
 JUEGO DE PIES cod. 74.9802.97.3 (opción)



CARATTERISTICHE - FEATURES

PERFORMANCE CHART

MODELLO MODEL CODICE PART NR.	MAX		PRESS		RPM 550				RPM 750				RPM 1000				PIST. PLUNG. Dia. mm	CORSA STROKE mm
	L/min	GPM	Bar	PSI	L/min	GPM	KW	HP	L/min	GPM	KW	HP	L/min	GPM	KW	HP		
CAX 2475 74.1016.97.3(*)	25	6.5	650	9425	14	3.7	17.7	23.7	19	4.9	23.8	32.0	25	6.5	31.5	42.2	16	44
			700	10150	14	3.6	18.9	25.4	19	4.9	25.5	34.2	25	6.5	33.7	45.2		
			750	10875	14	3.6	20.2	27.0	18	4.9	27.2	36.5	24	6.4	35.9	48.2		
CAX 3060 74.1010.97.3(*)	31	8.2	500	7250	18	4.6	17.2	23.0	24	6.2	23.2	31.1	31	8.2	30.6	41.1	18	44
			550	7975	17	4.6	18.8	25.2	24	6.2	25.4	34.1	31	8.2	33.5	45.0		
			600	8700	17	4.6	20.4	27.4	23	6.2	27.6	37.0	31	8.2	36.4	48.8		

(*) Per specificare la versione aggiungere al codice:
 L = albero sinistro dia. 40 mm
 R = albero destro dia. 40 mm

(*) To specify the version pls. add to the last number:
 L = left side shaft dia. 40 mm
 R = right side shaft dia. 40 mm

(*) Pour spécifier la version ajouter à la réf.:
 L = arbre côté gauche dia. 40 mm
 R = arbre côté droit dia. 40 mm

(*) Para especificar la versión añadir a la referencia:
 L = cigüeñal a la izquierda dia. 40 mm
 R = cigüeñal a la derecha dia. 40 mm