

**160 l/min
42.3 GPM**

**200 BAR
2900 PSI**



CARATTERISTICHE - SPECIFICATIONS

IN	DIAMETER	∅	1" 1/2 BSP
	PRESS.	Min.	-0.2 bar - 3 PSI
		Max.	6 bar 87 PSI
TEMP.	Max.	60° C. 140° F.	
OUT	DIAMETER	∅	1" BSP
SHAFT		∅	35 mm
OIL	SAE 75W90		2.8 litri 0.74 U.S.G.
PESO WEIGHT		Kg / lbs	55 / 121.3

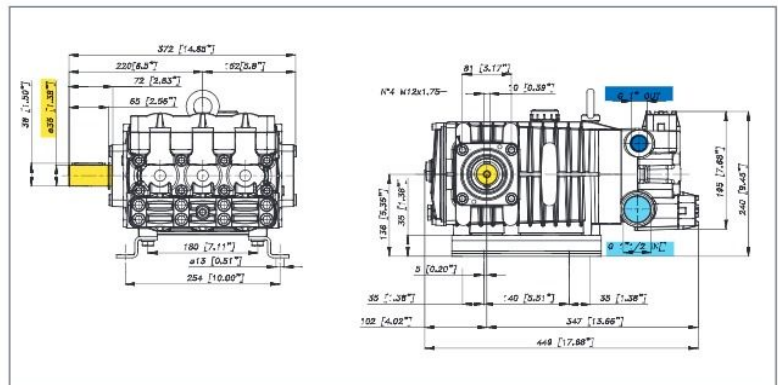

CARATTERISTICHE - FEATURES

PERFORMANCE CHART

MODELLO MODEL CODICE PART NR.	MAX		PRESS		RPM 700				RPM 850				RPM 1000				PIST. PLUNG. Dia. mm	CORSA STROKE mm
	L/min	GPM	Bar	PSI	L/min	GPM	KW	HP	L/min	GPM	KW	HP	L/min	GPM	KW	HP		
CPQ 9020 73.8626.97.3(*)	90	23.8	150	2175	63	16.5	18.5	24.7	76	20.2	22.5	30.2	90	23.8	26.5	35.6	30	44
			180	2610	62	16.5	22.0	29.5	75	19.8	26.5	35.5	87	23.1	30.9	41.4		
			200	2900	62	16.4	24.4	32.7	75	19.7	29.3	39.2	87	22.9	34.1	45.7		
CPQ 1316 73.8628.97.3(*)	130	34.3	100	1450	90	23.8	17.7	23.8	110	29.1	21.6	29.0	130	34.3	25.5	34.1	36	44
			130	1885	90	23.7	22.9	30.7	108	28.5	27.5	36.9	126	33.3	32.1	43.1		
			160	2320	89	23.6	28.1	37.6	107	28.3	33.7	45.2	125	33.0	39.2	52.6		
CPQ 1413 73.8629.97.3(*)	146	38.4	90	1305	101	26.7	17.9	24.0	123	32.6	21.8	29.3	146	38.4	25.7	34.5	40	40
			110	1595	101	26.6	21.8	29.2	121	32.0	26.1	35.1	141	37.3	30.5	40.9		
			130	1885	100	26.5	25.6	34.3	120	31.8	30.7	41.2	140	37.0	35.8	48.0		
CPQ 1613 73.8630.97.3(*)	160	42.3	90	1305	111	29.4	19.7	26.4	136	35.9	24.0	32.2	160	42.3	28.3	37.9	40	44
			110	1595	111	29.3	23.9	32.1	133	35.2	28.8	38.6	155	41.1	33.6	45.0		
			130	1885	110	29.1	28.1	37.7	132	35.0	33.8	45.3	154	40.7	39.4	52.8		

(*) Per specificare la versione aggiungere al codice:
L = albero sinistro dia.35 mm
R = albero destro dia.35 mm

(*) To specify the version pls. add to the last number:
L = left side shaft dia.35 mm
R = right side shaft dia.35 mm

(*) Pour spécifier la version ajouter à la réf.:
L = arbre côté gauche dia.35 mm
R = arbre côté droit dia.35 mm

(*) Para especificar la versión añadir a la referencia:
L = cigüeñal a la izquierda dia.35 mm
R = cigüeñal a la derecha dia.35 mm