

Serie CX

CX

IntelliSeal™

EasyLube™

SmartCase™

LifeTimeRod™

Pompa a 3 pistoni in ceramica. "P" Albero scanalato 1" 3/8 anteriore e posteriore.

3 ceramic piston pump. "P": spline thru shaft 1" 3/8

Насос с 3 керамическими поршнями. "P" Шлицевой вал 1" 3/8 спереди и сзади.

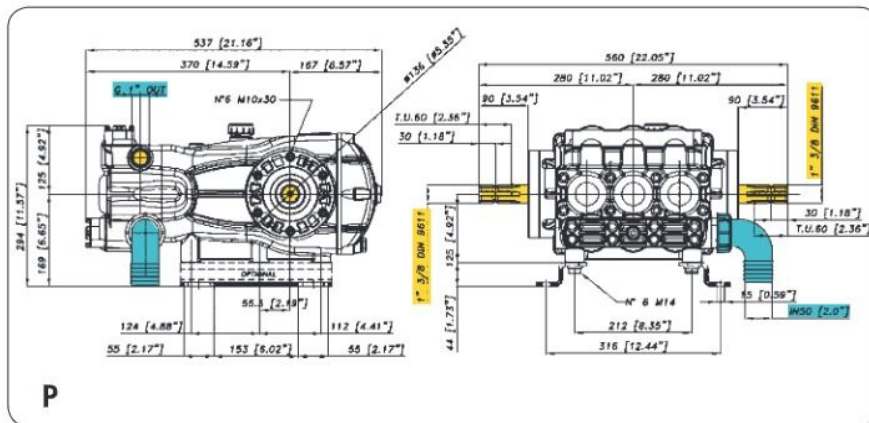

ACCESSORI - ACCESSORIES - АКЦЕССУАРЫ

Caratteristiche tecniche Specifications Технические характеристики

g/min; R.P.M.; об/мин	g/min	R.P.M.	550	550	
Potenza - Power - Мощность	KW	HP	18,6	24,8	
Peso - Weight - Вес	Kg	lb	55	121	
Dislivello aspirazione Negative pressure	MAX	mt	ft	1,5	4,9
Перепад уровней	Servizio discontinuo - Discontinuous Service - Прерывистая работа	mt	ft	3	9,8
Ø Aspirazione - Ø Intake - Ø Вход		mm	in	50	2"
Ø Mandata - Ø High pressure - Ø Выход		mm	in	G.1"	G.1"
Max. Temperatura - Max temperature - Температура		°C	°F	60	140
Tipo olio - Oil type - Тип масла	SAE	W	SAE30	30 W	
Capacità olio - Oil capacity - Объем масла	lt	U.S.G.	6	1,58	



Serie CX

CX 130

TABELLA RENDIMENTI - PERFORMANCE CHART ТАБЛИЦА ПРОИЗВОДИТЕЛЬНОСТИ									
g/min; R.P.M.; об/мин		400		450		500		550	
BAR	P.S.I.	L/min USGPM	KW HP	L/min USGPM	KW HP	L/min USGPM	KW HP	L/min USGPM	KW HP
2	29	104,7	0,4	117,8	0,5	130,9	0,5	144,0	0,6
		27,7	0,5	31,1	0,6	34,6	0,7	38,0	0,8
30	435	103,6	6,1	116,6	6,9	129,5	7,6	142,5	8,4
		27,4	8,2	30,8	9,2	34,2	10,2	37,6	11,2
50	725	102,9	10,1	115,8	11,4	128,6	12,6	141,5	13,9
		27,2	13,5	30,6	15,2	34,0	16,9	37,4	18,6
70	1015	101,1	13,9	113,7	15,6	126,4	17,4	139,0	19,1
		26,7	18,6	30,0	20,9	33,4	23,2	36,7	25,5

 **144** **38.0**
l/min USGPM

 **70** **1015**
bar P.S.I.

74.1009.97.3 - P

CX 150

TABELLA RENDIMENTI - PERFORMANCE CHART ТАБЛИЦА ПРОИЗВОДИТЕЛЬНОСТИ									
g/min; R.P.M.; об/мин		400		450		500		550	
BAR	P.S.I.	L/min USGPM	KW HP	L/min USGPM	KW HP	L/min USGPM	KW HP	L/min USGPM	KW HP
2	29	110,5	0,4	124,4	0,5	138,2	0,5	152,0	0,6
		29,2	0,6	32,9	0,7	36,5	0,7	40,2	0,8
30	435	109,8	6,5	123,5	7,3	137,3	8,1	151,0	8,9
		29,0	8,6	32,6	9,7	36,3	10,8	39,9	11,9
50	725	108,4	10,6	121,9	12,0	135,5	13,3	149,0	14,6
		28,6	14,2	32,2	16,0	35,8	17,8	39,4	19,5
70	1015	107,6	14,8	121,1	16,6	134,5	18,5	148,0	20,3
		28,4	19,8	32,0	22,2	35,5	24,7	39,1	27,2

 **152** **40.2**
l/min USGPM

 **70** **1015**
bar P.S.I.

74.1008.97.3 - P

CX 170

TABELLA RENDIMENTI - PERFORMANCE CHART ТАБЛИЦА ПРОИЗВОДИТЕЛЬНОСТИ									
g/min; R.P.M.; об/мин		400		450		500		550	
BAR	P.S.I.	L/min USGPM	KW HP	L/min USGPM	KW HP	L/min USGPM	KW HP	L/min USGPM	KW HP
2	29	120,0	0,5	135,0	0,5	150,0	0,6	165,0	0,6
		31,7	0,6	35,7	0,7	39,6	0,8	43,6	0,9
30	435	118,5	7,0	133,4	7,9	148,2	8,7	163,0	9,6
		31,3	9,3	35,2	10,5	39,1	11,7	43,1	12,8
50	725	117,8	11,6	132,5	13,0	147,3	14,5	162,0	15,9
		31,1	15,5	35,0	17,4	38,9	19,3	42,8	21,3
70	1015	116,4	16,0	130,9	18,0	145,5	20,0	160,0	22,0
		30,7	21,4	34,6	24,0	38,4	26,7	42,3	29,4

 **165** **43.6**
l/min USGPM

 **70** **1015**
bar P.S.I.

74.1003.97.3 - P