

# highest state PRECISION ALL OF THE ART TMG 1" highest quality PRECISION

## CARATTERISTICHE - SPECIFICATIONS

IN	DIAMETER	Ø	1/2 BSP
	PRESS.	Min.	1 bar 15 PSI
		Max.	6 bar 87 PSI
TEMP.	Max.	60° C. 140° F.	
OUT	DIAMETER	Ø	3/8 BSP
SHAFT		Ø	HOLLOW 1"
OIL		SAE 75W 90	0.7 litri 0.18 U.S.G.
PESO WEIGHT		Kg / lbs	10.8 / 23.7



**M SAE J609 -1"**

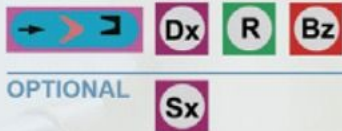
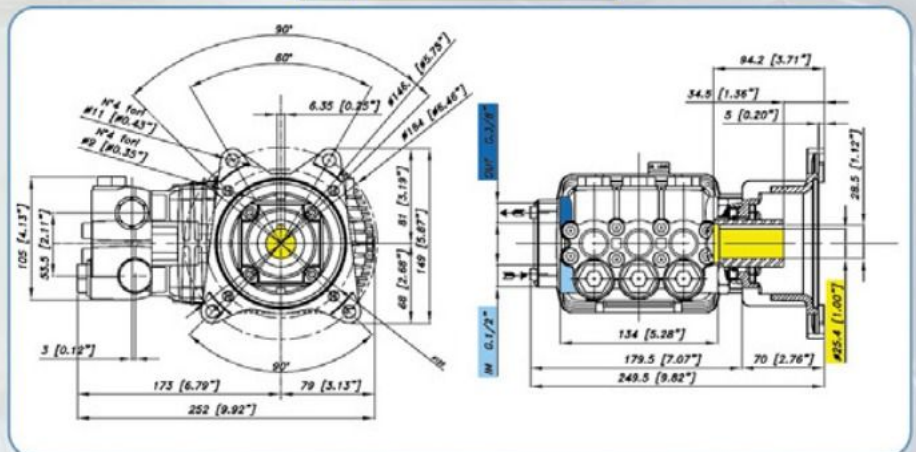

OPTIONAL

## TMG 1" 3450 rpm

### CARATTERISTICHE - FEATURES

### PERFORMANCE CHART

CODICE PART NR.	MODELLO MODEL	PRESS MAX / MAX PRESSURE		PORTATA / FLOW		POTENZA / POWER			PIST. PLUNG. Dia. mm	CORSA STROKE mm
		Bar	PSI	L/min	GPM	KW	HP	HP engine		
07.1600.97.A	TMG 3535	240	3500	13.2	3.5	6.3	8.5	11	15	8.6
07.1601.97.A	TMG 4035	280	4000	13.2	3.5	7	9.5	13	15	8.6
07.1602.97.A	TMG 3540	240	3500	15.2	4	7	9.6	13	15	9.8
07.1603.97.A	TMG 4040	280	4000	15.2	4	8.1	11	14.5	15	9.8
07.1604.97.A	TMG 3545	240	3500	17	4.5	6	8.1	14	15	11.2
07.1605.97.A	TMG 4045	280	4000	17	4.5	9.2	12.5	16	15	11.2
07.1606.97.A	TMG 3550	240	3500	19	5	8.8	12	16	15	12.4
07.1607.97.A	TMG 4050	280	4000	19	5	9.9	13.5	18	15	12.4
07.1608.97.A	TMG 3555	240	3500	21	5.5	9.9	13.5	18	15	14