

highest state  
 customized PRECISIONAL ART  
 highest customized  
**WMS/WMS-F**

**CARATTERISTICHE - SPECIFICATIONS**

		WMS	WMS-F
IN	DIAMETER	1/2 BSP	1/2 BSP
	PRESS.	Min. -0.1 bar -1.5 PSI	1 bar 15 PSI
		Max. 6 bar 87 PSI	6 bar 87 PSI
TEMP.	Max. 60° C. 140° F.		
OUT	DIAMETER	3/8 BSP	
SHAFT		24 mm	
OIL	SAE 75W 90	0.6 litri	0.16 U.S.G.
PESO WEIGHT	Kg lbs	7 / 14.4	



WMS Dx T B

WMS-F Dx B Bz

OPTIONAL Sx Bz M G

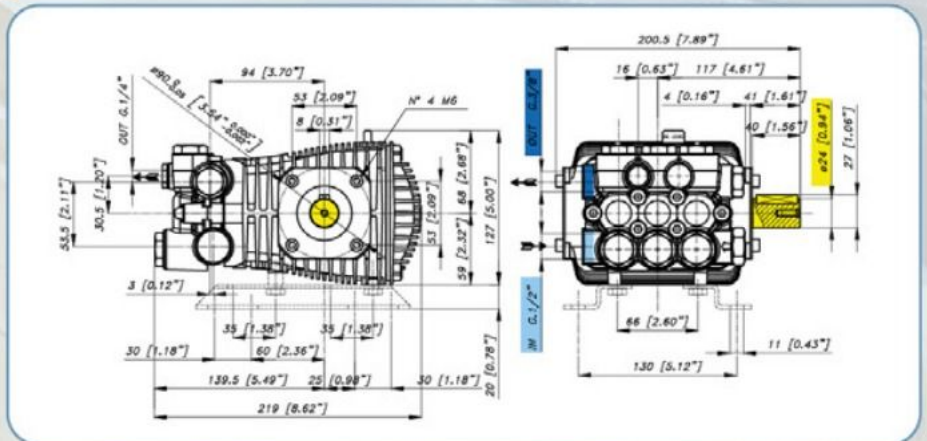

**WMS 1725 rpm**

**CARATTERISTICHE - FEATURES**

**PERFORMANCE CHART**

CODICE PART NR.	MODELLO MODEL	PRESS MAX / MAX PRESSURE		PORTATA / FLOW		POTENZA / POWER		PIST. PLUNG. Dia. mm	CORSA STROKE mm
		Bar	PSI	L/min	GPM	KW	HP		
04.8200.97.3	WMS 2530	170	2500	11.4	3	3.6	5	18	9.2
04.8201.97.3	WMS 2035	140	2000	13.2	3.5	3.6	5	18	10.8
04.8202.97.3	WMS 2535	170	2500	13.2	3.5	4.1	5.5	18	12.4
04.8203.97.3	WMS 2040	140	2000	15.2	4	4.1	5.5	18	12.4
04.8204.97.3	WMS 2540	170	2500	15.2	4	5.1	7	18	12.4

**WMS-F 3450 rpm**

04.8400.97.3	WMS 2035 F	140	2000	13.2	3.5	3.6	5	15	8
04.8401.97.3	WMS 2535 F	170	2500	13.2	3.5	4	5.5	15	9.2
04.8402.97.3	WMS 2040 F	140	2000	15.2	4	4	5.5	15	10.8
04.8403.97.3	WMS 2540 F	170	2500	15.2	4	4.8	6.5	15	10.8
04.8404.97.3	WMS 2045 F	140	2000	17	4.5	4.4	6	15	10.8
04.8405.97.3	WMS 2545 F	170	2500	17	4.5	5.5	7.5	15	10.8