

MB 180



construction materials: PP - PVDF



PP

Intake connection	G 2" 1/2 f		
Delivery connections	G 2 m		
Max. flow rate*	75 m ³ /h		
Max. head*	38 m		
Seal	TL-TS		
Motor power	11 kW - HP 15		
Motor	IP55 - F Class - 2-pole - 400/690 V 50 Hz - three-phase - 2900 RPM		
Diameter of passing solids	9 mm		
Max. viscosity	500 cps		
Net weight	PP	96 Kg	60°C Max. temp.
	PVDF	99 Kg	95°C Max. temp.

* The curves and performance values refer to pumps spare delivery outlet and water at 20°C.

TECHNICAL DATA

PERFORMANCE

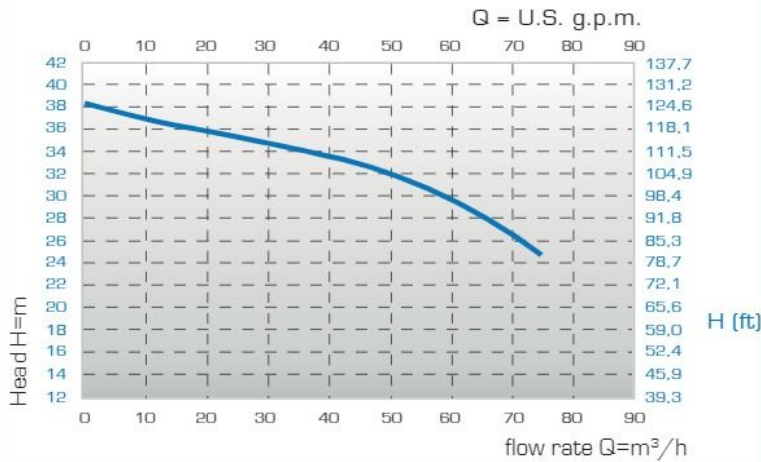

PVDF

DIMENSIONS

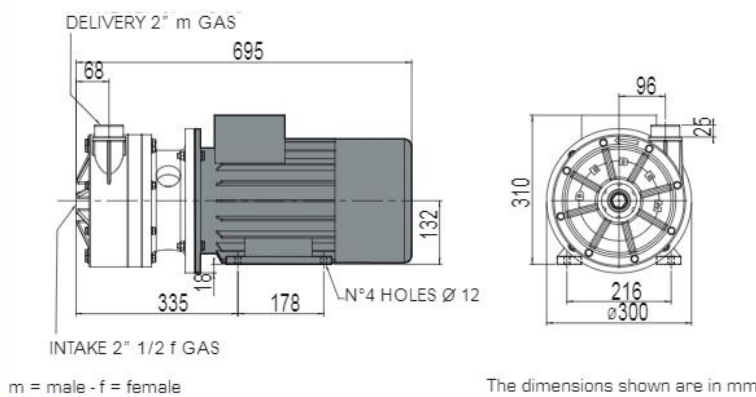

All the values shown are approximate and not binding