

"K PLUS" series metering pumps

Data Sheet



- Foot mounted
- Microprocessor technology
- Constant or proportional feeding
- Manual stroke length adjustment
- Manual venting (K) or self venting (KA) pump head
- EnclosurePP
- Environment temperature.....10-45°C (55-113°F)
- Chemical temperature.....0-50°C (32-122°F)
- Transportation and storage temperature-10-50°C (14-122°F)
- Altitude2000 m
- Installation classII
- Pollution level2
- Audible noise.....73.4 db(A)
- Protection degreeIP65 (% working RU: 85% T<=40°C; 70% T=50°C - without condensing water)

Configuration Code

MODELS			
Code K	Code KA	MOD.	DESCRIPTION
MU	AU	K PLUS	Constant proportional pump with level control. Working mode: - constant - constant with divider (1/10) - pulse divider (1/10; 10/100; 100/1000) - pulse multiplier (1/10) - mA signal current (0/4 mA = 0 pulses; 20mA = max pulses)
PO	PA	KCO PLUS	Constant pump with speed reducer (1/10)
PL	UA	KCL PLUS	Constant pump with level control. Speed reducer (1/10)

CAPACITIES				
K			Hoses	Pump head
2001	1 l/h at 20 bar	0.26 GPH at 290 PSI	4 x 6	I
1802	2 l/h at 18 bar	0.53 GPH at 261 PSI	4 x 6	L
1504	4 l/h at 15 bar	1.06 GPH at 217 PSI	4 x 6	L
1005	5 l/h at 10 bar	1.32 GPH at 102 PSI	4 x 6	L
0808	8 l/h at 8 bar	2.11 GPH at 116 PSI	4 x 6	L
0510	10 l/h at 5 bar	2.64 GPH at 58 PSI	4 x 6	L
0218	18 l/h at 2 bar	4.76 GPH at 29 PSI	6 x 8	M
KA			Hoses	Pump head
1801	1 l/h at 18 bar	0.26 GPH at 261 PSI	4 x 6	LA
1503	3 l/h at 15 bar	0.79 GPH at 217 PSI	4 x 6	LA
103.5	3.5 l/h at 10 bar	0.92 GPH at 102 PSI	4 x 6	LA
100.5	0.5 l/h at 10 bar	0.13 GPH at 102 PSI	4 x 6	JA
085.5	5.5 l/h at 8 bar	1.45 GPH at 116 PSI	4 x 6	LA
057.5	7.5 l/h at 5 bar	1.98 GPH at 58 PSI	4 x 6	LA
0213	13 l/h at 2 bar	3.43 GPH at 29 PSI	6 x 8	MA

Model **K** **MU** **2001** **K** **00** **00**

LIQUID ENDS								
	HEAD	ORINGS	VALVE		DIAPHRAGM	HOSES ¹		VISCOSITY Max CPS
			Body	Balls		Delivery	Suction	
K	PVDF	FKM B	PVDF	Ceramic	PTFE	PVDF	PVC	100
P	PVDF	EPDM	PVDF	Ceramic	PTFE	PVDF	PVC	100
Y	PVDF	Nitrile	PVDF	Ceramic	PTFE	PVDF	PVC	100
V	PP	FKM B	PP	Ceramic	PTFE	PVDF	PVC	100
D	PP	EPDM	PP	Ceramic	PTFE	PE	PVC	100
W	PP	Nitrile	PP	Ceramic	PTFE	PE	PVC	100
J	PVDF	FKM B + PTFE	PVDF	Ceramic	PTFE	PVDF	PVC	100
M	PVDF	EPDM + PTFE	PVDF	Ceramic	PTFE	PVDF	PVC	100
A	Acrylic	FKM B	PVDF	Ceramic	PTFE	PVDF	PVC	100
Z	SS	FKM B	SS	SS	PTFE	N/A	N/A	100
\$	Acrylic	FKM B	PP	SS + Hastelloy spring	PTFE	PP	PVC	8000 ²

POWER SUPPLY	
00	230 VAC Schuko plug
05	230 VAC Australian plug
01	230 VAC without plug
03	115 VAC US plug
04	24 VAC without plug
05	12 VDC *
07	24 VDC

* On some models only.

¹ Size may be different from standard.
² Using high viscosity pump head mod. \$, pump output may result lower in some applications.



Technical features

INFORMATION FOR K PLUS								
Models	Strokes speed		Stroke length range reliability	Power consumption at max flow (230 VAC)	Power consumption at max flow (115 VAC)	Power consumption at max flow (24 VAC)	Power consumption at max flow (12 VAC)	Weight
	min	max						
2001	18	180	from 30% to 100%	19 Watt	24 Watt	12 Watt	8.8 Watt	4.1 Kg (9.02 Lbs)
1802	18	180						
1504	18	180						
1005	18	180						
0808	18	180						
0510	18	180						
0501	18	180						
0218	18	180						
INFORMATION FOR KA MODELS								
1801	18	180	from 30% to 100%	19 Watt	24 Watt	12 Watt	8.8 Watt	4.1 Kg (9.02 Lbs)
1503	18	180						
103.5	18	180						
100.5	18	180						
085.5	18	180						
057.5	18	180						
0213	18	180						

CAPACITY									
K PLUS	FLOW				cc per STROKE		Maximum pressure		
	min cc/h	max l/h	Min GPH	Max GPH	min	max	bar	PSI	
	2001	30	1	0,01	0,26	0,03	0,09	20	290
1802	60	2	0,02	0,53	0,06	0,19	18	261	
1504	120	4	0,03	1,1	0,1	0,37	15	217,5	
1005	150	5	0,04	1,3	0,1	0,46	10	145	
0808	240	8	0,06	2,1	0,2	0,74	8	116	
0510	300	10	0,08	2,6	0,3	0,93	5	72,5	
0501	30	1	0,01	0,3	0	0,09	5	72,5	
0218	540	18	0,14	4,8	0,5	1,67	2	29	

CAPACITY									
KA PLUS	FLOW				cc per STROKE		Maximum pressure		
	min cc/h	max l/h	Min GPH	Max GPH	min	max	bar	PSI	
	1801	30	1	0,01	0,26	0,03	0,09	18	261
1503	90	3	0,02	0,79	0,08	0,28	15	217,5	
103.5	105	3,5	0,03	0,9	0,1	0,32	10	145	
100.5	15	0,5	0,0039	0,13	0,1	0,32	10	145	
085.5	165	5,5	0,05	1,5	0,2	0,51	8	116	
057.5	225	7,5	0,06	2	0,2	0,69	5	72,5	
0213	390	13	0,1	3,4	0,4	1,2	2	29	

QUANTITY	PACKAGE CONTENT
n. 1	Assembly kit
n. 1	5 X 20 delayed fuse
n. 1	Level probe with axial foot filter (PVDF) - level probe not in KCO PLUS mod.
n. 1	0,3 Bar injection valve (PVDF)
m 2	Delivery hose
m 2	Suction hose
m 2	Discharge hose
m 2,5	Input signal cable (only K PLUS)
n.1	Operating manual

POWER SUPPLY	FUSE
230 VAC (190-265 VAC) - 50/60 Hz	1 A
115 VAC (90-135 VAC) - 50/60 Hz	500 mA
24 VAC (20-32 VAC) - 50/60 Hz	2A
12 VDC (10-16 VDC)	3.15A

Dimension

mm [inches]

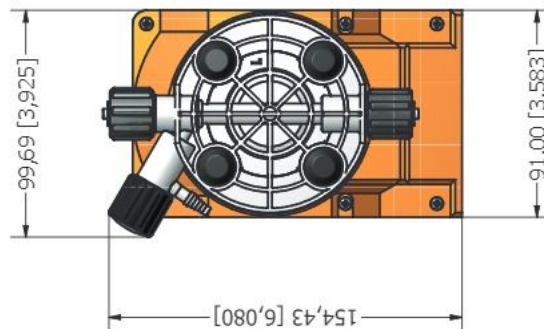
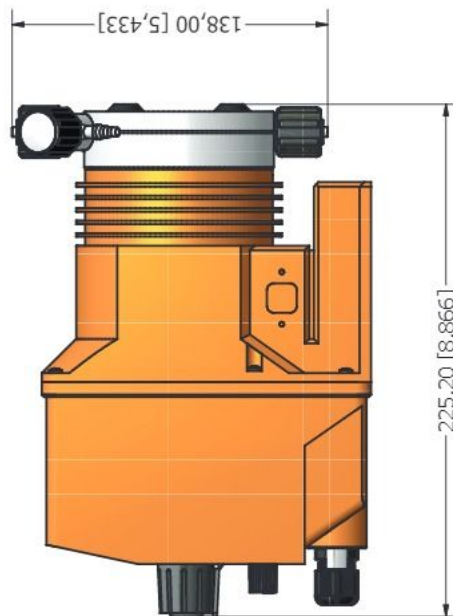
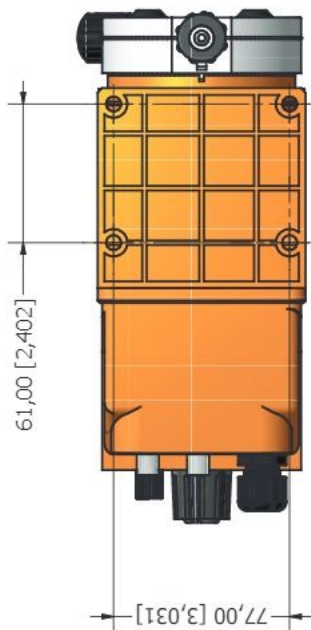
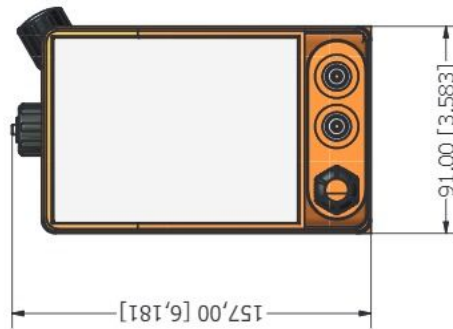

"KMS" and "KMSA" series metering pumps Data Sheet

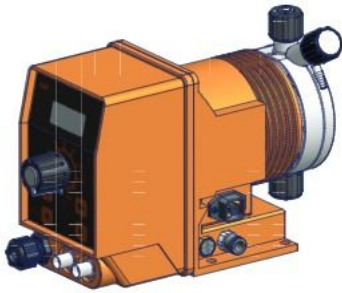

- Foot mounted
- Microprocessor technology
- Manual stroke length adjustment
- Manual venting (KMS) or self venting (KMSA) PVDF pump head
- Liquid ends (pump head, injection valve, foot filter, delivery hose).....PVDF
- EnclosurePP
- Environment temperature.....10-45°C (55-113°F)
- Chemical temperature.....0-50°C (32-122°F)
- Transportation and storage temperature.....-10-50°C (14-122°F)
- Installation classII
- Pollution level.....2
- Audible noise.....73.4db(A)
- Protection degreeIP65 (% working RU: 85% T<=40°C; 70% T=50°C - without condensing water)



MODELS			
KMS Code	KMSA Code	MOD.	DESCRIPTION
DC	AD	KMS DC	Digital constant pump, stand-by input and alarm output and level control.
MF	AF	KMS MF	Digital multifunction pump (Constant, Divide, Multiply, PPM, Batch, Volt, mA, %, ml/q), stand-by and flow sensor input, alarm output and level control. Recovery fault mode, work-pause mode and upkeep mode.
ML	LA	KMS CL	Proportional pump for free chlorine (Cl ₂) control (from 0 to 10,00 mg/l) with level control, supplied without chlorine probe. It operates with chlorine cells mod. ECL1 and ECL6/7/12 (not provided).
EN	AN	KMS EN	Pump with weekly timer, microprocessor, digital controls, LCD display, level probe and electrovalve control.
PH	MH	KMS PH	Proportional pump driven by internal built-in pH meter (0-14 pH) and level control, supplied without pH probe.
RH	AR	KMS RH	Proportional pump driven by internal built-in ORP meter (0-1000 mV) and level control, supplied without ORP probe.

CAPACITIES				
	KMS		Hoses	Pump head
2001	1 l/h at 20 bar	0.26 GPH at 290 PSI	1/4"	I
1802	2 l/h at 18 bar	0.53 GPH at 261 PSI	1/4"	L
1504	4 l/h at 15 bar	1.06 GPH at 217 PSI	3/8"	L
1005	5 l/h at 10 bar	1.32 GPH at 102 PSI	3/8"	L
0808	8 l/h at 8 bar	2.11 GPH at 116 PSI	3/8"	L
0510	10 l/h at 5 bar	2.64 GPH at 58 PSI	3/8"	L
0218	18 l/h at 2 bar	4.76 GPH at 29 PSI	1/2"	M
	KMSA		Hoses	Pump head
1801	1 l/h at 18 bar	0.26 GPH at 261 PSI	1/4"	LA
1503	3 l/h at 15 bar	0.79 GPH at 217 PSI	3/8"	LA
103.5	3.5 l/h at 10 bar	0.92 GPH at 102 PSI	3/8"	LA
100.5	0.5 l/h at 10 bar	0.13 GPH at 102 PSI	3/8"	JA
085.5	5.5 l/h at 8 bar	1.45 GPH at 116 PSI	3/8"	LA
057.5	7.5 l/h at 5 bar	1.98 GPH at 58 PSI	3/8"	LA
0213	13 l/h at 2 bar	3.43 GPH at 29 PSI	3/8"	MA

K MF 2001 K 00 00

LIQUID ENDS								
	HEAD	ORINGS	VALVE		DIAPHRAGM	HOSES ¹		VISCOSITY Max CPS
			Body	Balls		Delivery	Suction	
K	PVDF	FKM B	PVDF	Ceramic	PTFE	PVDF	PVC	100
P	PVDF	EPDM	PVDF	Ceramic	PTFE	PVDF	PVC	100
Y	PVDF	Nitrile	PVDF	Ceramic	PTFE	PVDF	PVC	100
V	PP	FKM B	PP	Ceramic	PTFE	PVDF	PVC	100
D	PP	EPDM	PP	Ceramic	PTFE	PE	PVC	100
W	PP	Nitrile	PP	Ceramic	PTFE	PE	PVC	100
J	PVDF	FKM B + PTFE	PVDF	Ceramic	PTFE	PVDF	PVC	100
S	PVDF	Silicone	PVDF	Ceramic	PTFE	PVDF	PVC	100
A	Acrylic	FKM B	PVDF	Ceramic	PTFE	PVDF	PVC	100
Z	SS ³	FKM B	SS	SS	PTFE	N/A	N/A	100
\$	Acrylic	FKM B	Polypropylene	SS + Hastelloy spring	PTFE	Polyethylen	PVC	8000 ²

¹ Size may be different from standard.
² Using high viscosity pump head mod. \$, pump output may results lower in some applications.
³ Specify on order, the external thread of the valves: conical, cylindrical or NPT. Stainless Steel pump does not fit installation kit (accessories and hoses). Refer to "SS Accessories" table for fittings.

POWER SUPPLY	
00	230 VAC Schuko plug
05	230 VAC Australian plug
01	230 VAC without plug
03	115 VAC US plug
04	24 VAC without plug
05	12 VDC *
07	24 VDC

* On some models only.

SS ACCESSORIES ³	
Pump head	Fittings
Li	3/8"
Mi	1/2"
Ni	1/2"
Si	3/4"
Ti	3/4"

EMEC

ISO 9001:2015
 ISO 14001:2004
 OHSAS 18001:2007



Via Donatori di sangue, 1 - 02100 Rieti - Italy
 Tel. +39 0746 2284 1 - Fax +39 0746 2284 2 - http://www.emecpumps.com

Specifications subject to change without notice.
 EN R1-04-18

"KMS" and "KMSA" series metering pumps Data Sheet

Technical features

KMS MODELS								
Models	Strokes speed		Stroke length range reliability	Power consumption at max flow (230 VAC)	Power consumption at max flow (115 VAC)	Power consumption at max flow (24 VAC)	Power consumption at max flow (12 VAC)	Weight
	min strokes hour	max strokes minute						
2001	1	180	from 30% to 100%	19 Watt	24 Watt	12 Watt	8.8 Watt	4.1 Kg (9.02 Lbs)
1802	1	180						
1504	1	180						
1005	1	180						
0808	1	180						
0510	1	180						
0218	1	180						
KMSA MODELS								
1801	1	180	from 30% to 100%	19 Watt	24 Watt	12 Watt	8.8 Watt	4.1 Kg (9.02 Lbs)
1503	1	180						
103.5	1	180						
100.5	1	180						
085.5	1	180						
057.5	1	180						
0213	1	180						

CAPACITY KMS MODELS									
Model	FLOW				cc per STROKE		Maximum pressure		Pump Head
	min cc/h	max l/h	Min GPH	Max GPH	min	max	bar	PSI	
2001	0.03	1	0.01	0.26	0.03	0.09	20	290	I
1802	0.06	2	0.02	0.53	0.06	0.19	18	261	L
1504	0.11	4	0.03	1.06	0.11	0.37	15	217	L
1005	0.14	5	0.04	1.32	0.14	0.46	10	145	L
0808	0.22	8	0.06	2.11	0.22	0.74	8	116	L
0510	0.28	10	0.07	2.64	0.28	0.93	5	58	L
0218	0.50	18	0.13	4.75	0.5	1.67	2	29	M

CAPACITY KMSA MODELS									
Model	FLOW				cc per STROKE		Maximum pressure		Pump Head
	min cc/h	max l/h	Min GPH	Max GPH	min	max	bar	PSI	
1801	0.03	1	0.01	0.26	0.03	0.09	18	261	LA
1503	0.08	3	0.02	0.79	0.08	0.28	15	217	LA
103.5	0.10	3.5	0.03	0.92	0.1	0.32	10	145	LA
100.5	0.02	0.5	0.01	0.13	0.02	0.05	10	145	JA
085.5	0.15	5.5	0.04	1.45	0.15	0.51	8	116	LA
057.5	0.21	7.5	0.06	1.98	0.21	0.69	5	58	LA
0213	0.37	13	0.1	3.43	0.36	1.2	2	29	MA

QUANTITY	PACKAGE CONTENT
n. 1	Assembly kit
n. 1	5 X 20 delayed fuse
n. 1	Level probe with axial foot filter (PVDF)
n. 1	0,3 Bar injection valve (PVDF)
m 2	Delivery hose
m 2	Suction hose
m 2	Discharge hose
m 2,5	Input signal cable
m 2	Alarm/Stand-by cable (MF model)
n.1	Operating manual

POWER SUPPLY	FUSE
230 VAC (190-265 VAC) - 50/60 Hz	1 A
115 VAC (90-135 VAC) - 50/60 Hz	500 mA
24 VAC (20-32 VAC) - 50/60 Hz	2A
12 VDC (10-16 VDC)	3.15A

EMEC

ISO 9001:2015
ISO 14001:2004
OHSAS 18001:2007



Via Donatori di sangue, 1 - 02100 Rieti - Italy
Tel. +39 0746 2284 1 - Fax +39 0746 2284 2 - <http://www.emecpumps.com>

Specifications subject to change without notice.
EN R1-04-18

"KMS" and "KMSA" series metering pumps Data Sheet

Dimension

mm [inches]

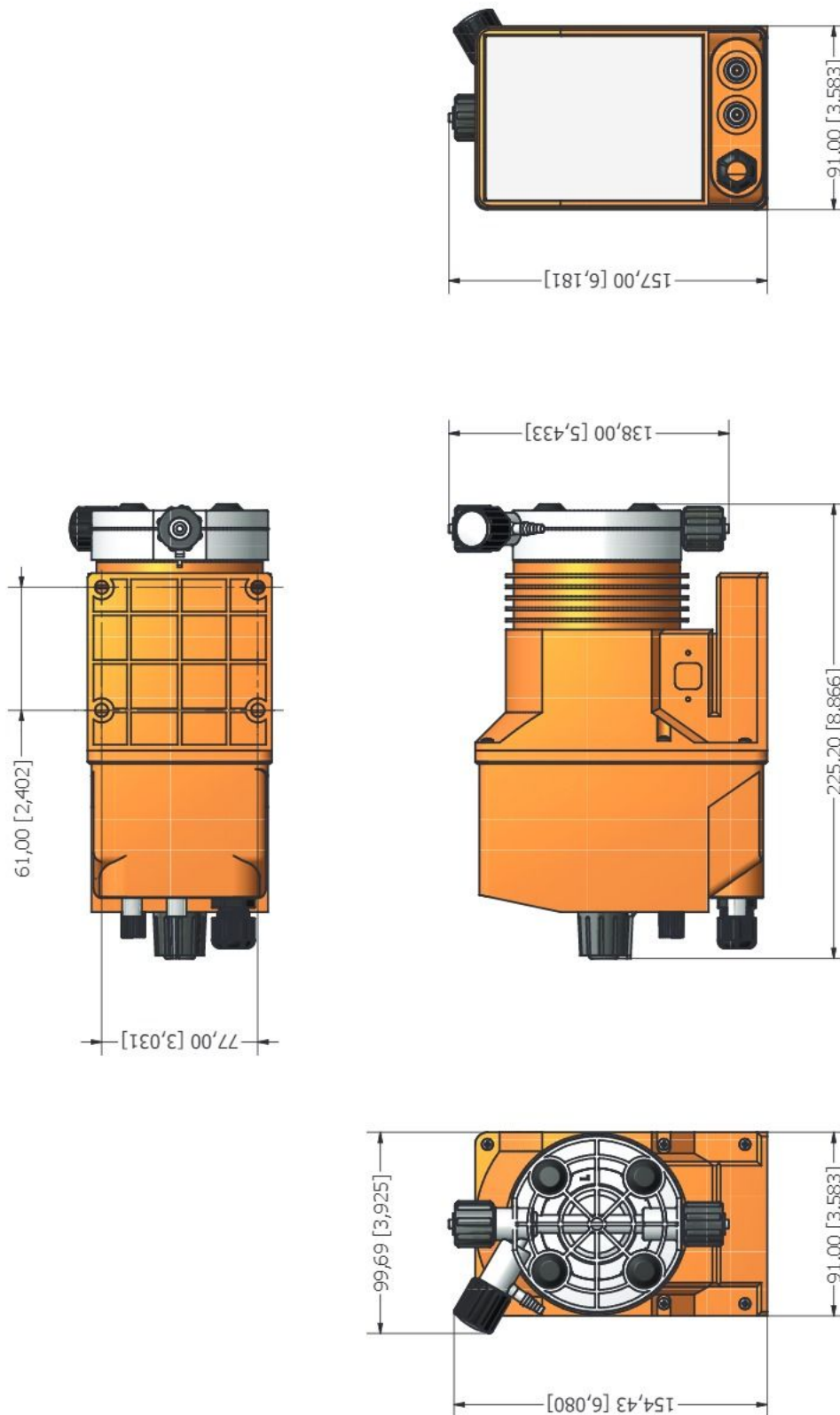

EMEC

ISO 9001:2015
ISO 14001:2004
OHSAS 18001:2007



Via Donatori di sangue, 1 - 02100 Rieti - Italy
Tel. +39 0746 2284 1 - Fax +39 0746 2284 2 - <http://www.emecpumps.com>

Specifications subject to change without notice.
EN R1-04-18