

CO Series

Threaded centrifugal pumps with open impeller. These pumps combine the advantages of an open impeller with those of AISI 316 stainless steel which is particularly suited for pumping moderately aggressive liquids containing suspended solids.

Specifications

Delivery: up to 54 m³/h
Head: up to 24 m
Power supply: three-phase and single-phase 50 and 60 Hz
Power: 0.37 kW to 3 kW
Maximum operating pressure: 8 bar
Temperature of pumped liquid: -10°C to +120°C
Insulation class: 155 (F)
Protection: IP55
Open impeller pumps solids up to:
CO350 - 11 mm
CO500 - 20 mm

Materials

Pump body: Stainless steel AISI 316L
Impeller: Stainless steel AISI 316L
Seal housing: Stainless steel AISI 316L
Mechanical seal: Ceramic/Carbon/FPM
Fill and drain plugs: Stainless steel
Elastomers: FPM

Applications

Washing of metal parts and/or surface treatment

Washing of produce in the packaging industry

Food industry washing equipment and systems

Dyeing plant and textile industry

Plants for the circulation and transfer of moderately viscous liquids, with light chemical aggressiveness

Industrial washing machine and commercial dishwashers



CO SERIES

Operating characteristics at 50 Hz

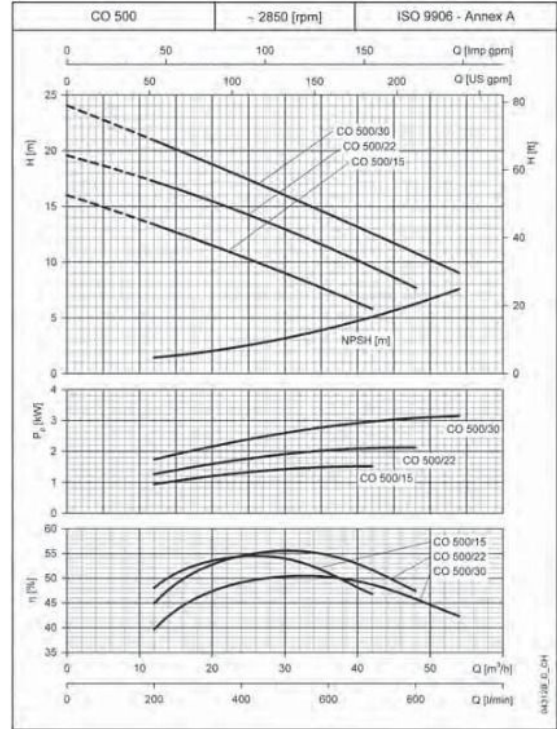
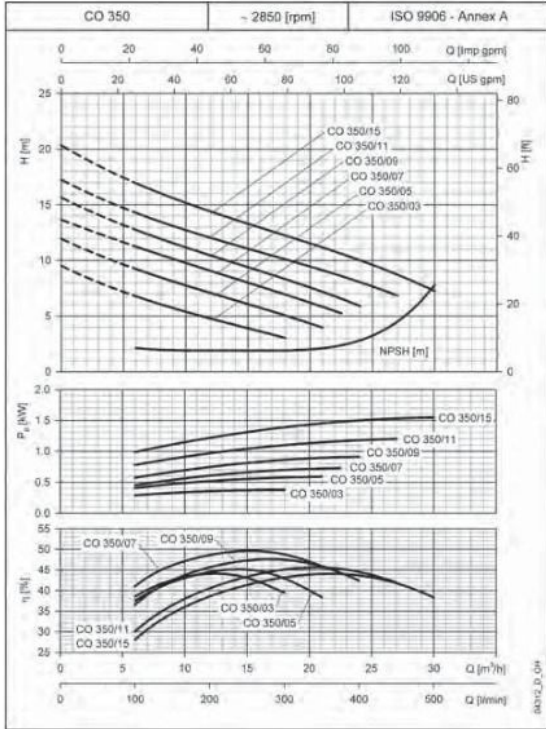

These performances are valid for liquids with density $\rho = 1.0 \text{ kg/dm}^3$ and kinematic viscosity $\nu = 1 \text{ mm}^2/\text{s}$.

CO SERIES Hydraulic performance table

PUMP TYPE	RATED POWER		Q = DELIVERY																		
			H = TOTAL HEAD IN COLUMN OF WATER (METRES)																		
	l/min	0	100	120	160	200	240	280	300	350	375	400	450	500	600	650	700	800	900		
		m ³ /h	0	6	7,2	9,6	12	14,4	16,8	18	21	22,5	24	27	30	36	39	42	48	54	
		kW	HP																		
CO(M) 350/03	0,37	0,5	9,5	6,8	6,3	5,5	4,8	4,1	3,4	3,0											
CO(M) 350/05	0,55	0,75	12,0	9,2	8,8	7,9	7,1	6,3	5,5	5,1	4,0										
CO(M) 350/07	0,75	1	13,7	11,2	10,8	9,9	9,1	8,2	7,4	6,9	5,8	5,3									
CO(M) 350/09	0,9	1,2	15,7	12,7	12,2	11,3	10,5	9,6	8,8	8,3	7,2	6,6	5,9								
CO(M) 350/11	1,1	1,5	17,3	14,3	13,8	12,9	12,0	11,2	10,5	10,1	9,1	8,6	8,0	6,8							
CO(M) 350/15	1,5	2	20,3	16,9	16,4	15,3	14,4	13,5	12,7	12,2	11,2	10,6	10,0	8,7	7,2						
CO(M) 500/15	1,5	2	16,0				13,4	12,8	12,3	12,0	11,3	10,9	10,5	9,8	9,0	7,4	6,6	5,8			
CO(M) 500/22	2,2	3	19,6				17,3	16,7	16,2	15,9	15,2	14,9	14,5	13,7	13,0	11,3	10,4	9,6	7,7		
CO 500/30	3	4	24,1				20,9	20,3	19,7	19,3	18,5	18,1	17,7	16,9	16,0	14,3	13,5	12,6	10,8	9,0	

co-2p50_d_th

Electrical data

PUMP TYPE	MOTOR TYPE	INPUT POWER*	INPUT CURRENT* 220-240 V	CAPACIT. μF / 450 V	PUMP TYPE	MOTOR TYPE	INPUT POWER*	INPUT CURRENT* 220-240 V	INPUT CURRENT* 380-415 V
		kW	A				kW	A	A
COM350/03	SM63BG/1045	0,63	2,82	14	C0350/03	SM63BG/304	0,64	2,53	1,46
COM350/05	SM71BG/1055	0,88	4,25	16	C0350/05	SM71BG/305	0,79	2,70	1,56
COM350/07	SM71BG/1075	1,02	4,67	20	C0350/07	SM80BG/307HE	0,98	3,10	1,79
COM350/09	SM71BG/1095	1,21	5,46	25	C0350/09	SM80BG/311HE	1,12	3,60	2,08
COM350/11	SM80BG/1115	1,75	7,85	30	C0350/11	SM80BG/311HE	1,67	4,90	2,83
COM350/15	SM80BG/1155	2,04	9,21	40	C0350/15	PLM90BG/315	1,91	5,69	3,29
COM500/15	SM80BG/1155	2,02	9,12	40	C0500/15	PLM90BG/315	1,89	5,62	3,25
COM500/22	PLM90BG/1225	2,72	12,7	70	C0500/22	PLM90BG/322	2,66	8,27	4,78
-	-	-	-	-	C0500/30	PLM90BG/330	3,80	11,4	6,57

*Maximum value in specified range.

co-2p50-en_e_te



CO SERIES Dimensions and weights

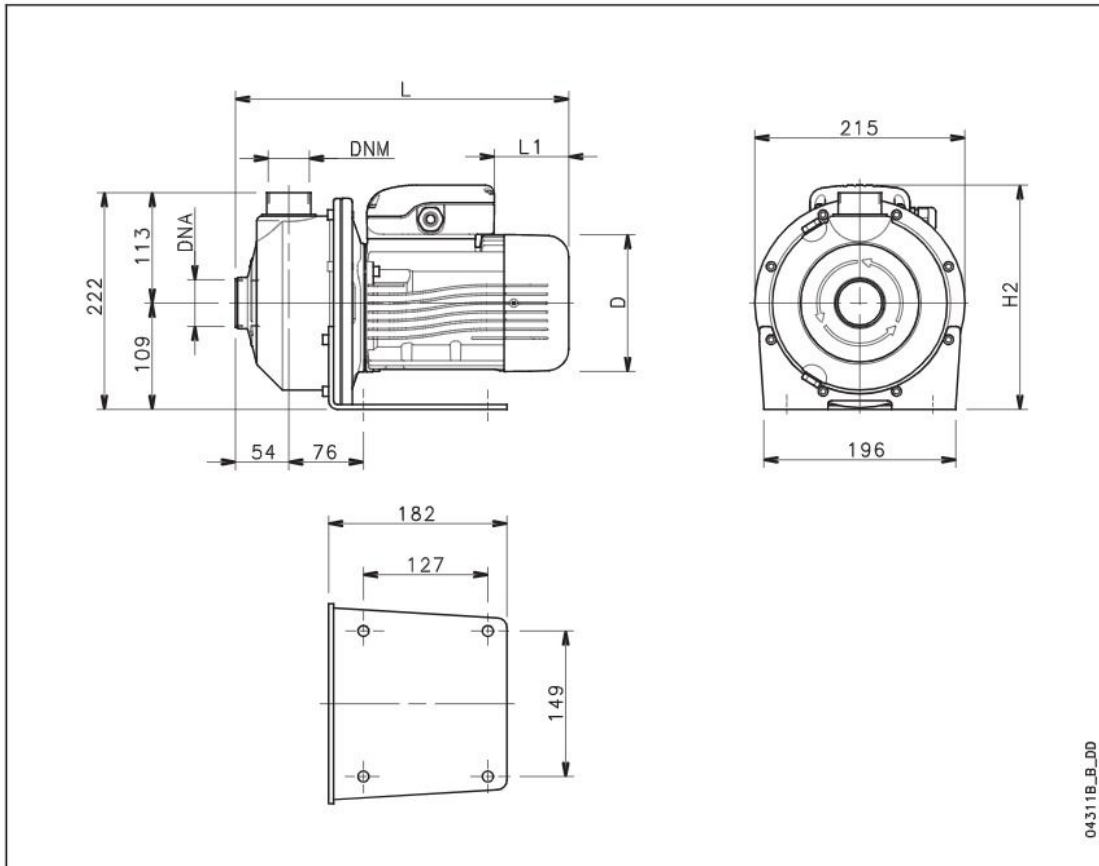

PUMP TYPE	DIMENSIONS (mm)				DNA	DNM	WEIGHT kg
	D	H2	L	L1			
COM 350/03	120	220	325	62	Rp 1½	Rp 1¼	10
COM 350/05	140	230	339	76	Rp 1½	Rp 1¼	11,9
COM 350/07	140	230	339	76	Rp 1½	Rp 1¼	12,6
COM 350/09	140	239	339	31	Rp 1½	Rp 1¼	13,2
COM 350/11	156	246	385	69	Rp 1½	Rp 1¼	14,5
COM 350/15	156	246	385	69	Rp 1½	Rp 1¼	16,2
COM 500/15	156	246	385	69	Rp 2	Rp 1½	16,2
COM 500/22	174	243	429	84	Rp 2	Rp 1½	20
CO 350/03	120	220	325	62	Rp 1½	Rp 1¼	10
CO 350/05	140	230	339	76	Rp 1½	Rp 1¼	11,9
CO 350/07	155	238	385	114	Rp 1½	Rp 1¼	15,5
CO 350/09	155	238	385	114	Rp 1½	Rp 1¼	15,5
CO 350/11	155	238	385	114	Rp 1½	Rp 1¼	17
CO 350/15	174	243	429	172	Rp 1½	Rp 1¼	21
CO 500/15	174	243	429	172	Rp 2	Rp 1½	21
CO 500/22	174	238	429	172	Rp 2	Rp 1½	23
CO 500/30	174	243	429	172	Rp 2	Rp 1½	25

co-2p50-en_e_td