



Control panel with inverter



Level sensor



I Application

The compact and robust design of the Kiber NTE pump makes it ideal for transferring whole or destemmed grapes. And due to its design it can be installed right under the destemmer. It also can be used for the process of devatting.

I Operating principle

Friction between the rotor and the stator creates vacuum in the inlet area thereby helping the entry of the product into the pump.

The turning motion of the rotor makes the cavities between the rotor and the stator move forward and transport the product to the outlet.

I Design and features

- Highly versatile.
- Easy to clean.
- Hopper with drain.
- Robust construction.
- Helical-bevel gear unit.
- Pump mounted on cart.
- EC electric panel with ON/OFF switch, inverter and emergency stop push button.
- Wheels with brake.
- Red painted RAI3003.

I Motor and gear unit

Helical-bevel gear unit and triphasic induction motor 4 poles=1500/1750 rpm, efficiency class according to EC regulation, IP 55 protection and F-class insulation.
3 phases, 50 Hz, 400 V Δ / 690 V Y

I Options

- Pump without handle and without control panel.
- Liquid detector: Max / Min.
- Remote control.
- Electromagnetic brake in motor.
- St.St. control panel.
- Frequency converter.
- Other connections.

I Technical specifications

Materials:

Parts in contact with the product	AISI 316L (1.4404)
Other steel parts	AISI 304 (1.4301)
Lantern	Carbon steel
Stator	NBR (specific composition for this application)
Sealing	PTFE packing



I Technical specifications

Surface finish	Blasted	
Connections	Spherical coupling	
Operating limits:		
Maximum flow	60 m ³ /h	264 US GPM
Maximum working pressure	6 bar	87 PSI
Maximum working temperature	85 °C	185 °F

Type	Flow* [Tn/h]	Speed [rpm]	Power [kW]	Weight [kg]
NTE-80	20/25	210	5,5	295
NTE-90	28/36	210	7,5	320
NTE-100	40/50	210	7,5	345

* Nominal flow for destemmed grapes at 2 - 4 bar

I Dimensions

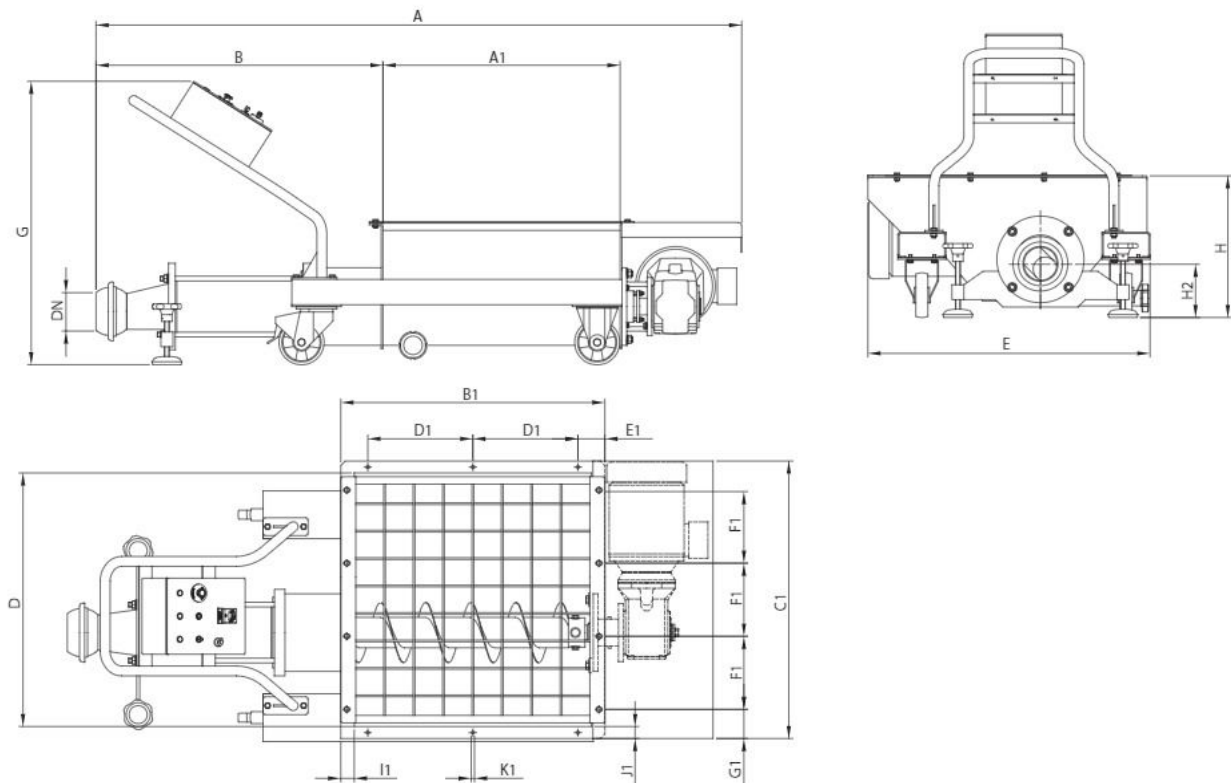

Type	DN	A	A1	B	D	E	G	H	H2
NTE-80	120	2150	790	955	850	950	950	475	180
NTE-90	120	2210	790	1015	850	950	950	475	170
NTE-100	150	2255	790	1060	850	950	950	475	165

Hopper dimensions								
B1	C1	D1	E1	F1	G1	I1	J1	K1
880	930	350	90	245	97,5	45	40	11

