



I Application

The SLRT pump is a positive displacement rotary lobe pump designed to discharge food and sanitary products from a truck cistern as it can be driven by a hydraulic motor.

The pump is characterised by a compact design, reduced weight and interchangeable connections to facilitate its assembly to a truck.

The SLRT pump is designed to pump liquid products with or without delicate solid particles that require gentle pumping causing no damage to the product.

I Design and features

The SLRT rotary lobe pumps basically consist of bi-lobe rotors which rotate synchronously inside a casing without touching each other.

As the rotors rotate, the spaces between the lobes and the casing are successively filled with the product and a fixed amount of the displaced product is conveyed to the discharge nozzle.

The pumped product forms a continuous flow thanks to the clearances between the lobes and the pump casing, thus, ensuring an efficient pumping.

The pump casing and the lobes are manufactured in stainless steel. The design of the attachments of the lobes is sanitary. The shaft is hollow with spline SAE 6B 1". The SLRT rotary lobe pump is supplied with a sanitary mechanical seal. It is characterised by easily cleaning and maintenance.

I Technical specifications

Materials:

Parts in contact with the product	AISI 316L
Support	GG 25
Legs	AISI 304
Gaskets	EPDM

Mechanical seal:

Rotary part	SiC
Stationary part	C
Gaskets	EPDM

Internal surface finish	Ra<0,8 µm
External surface finish	Matt

Connections:	DIN (interchangeable connections)
--------------	-----------------------------------



I Technical specifications

Operating limits:

Maximum flow	63 m ³ /h	277 US GPM
Maximum pressure	7 bar	102PSI
Maximum working temperature	120 °C	248 °F
Maximum speed	950 rpm	
Weight	70 kg	



I Options

- Mechanical seal: SiC/SiC or TungC/SiC.
- Shaft seal: PTFE.
- Gasket: FPM.
- Relief valve on the front cover or external bypass.
- Bare shaft for electrical drive.
- Vertical support.
- Connections: Clamp, SMS, RJT, etc.
- Heating jacket.

I Dimensions

Pump designed for hydraulic drive

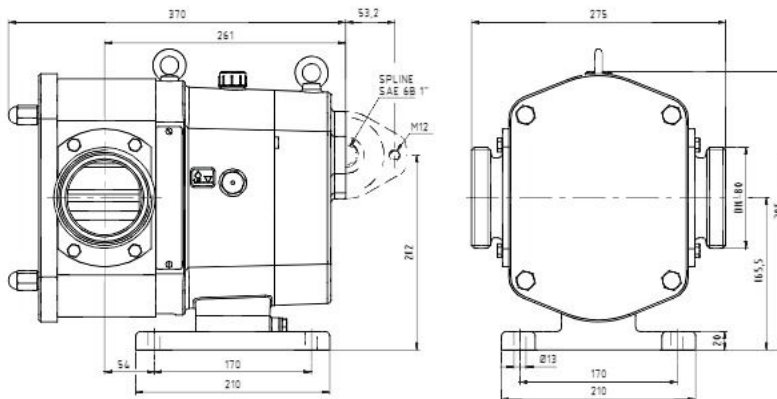

Pump with bare shaft

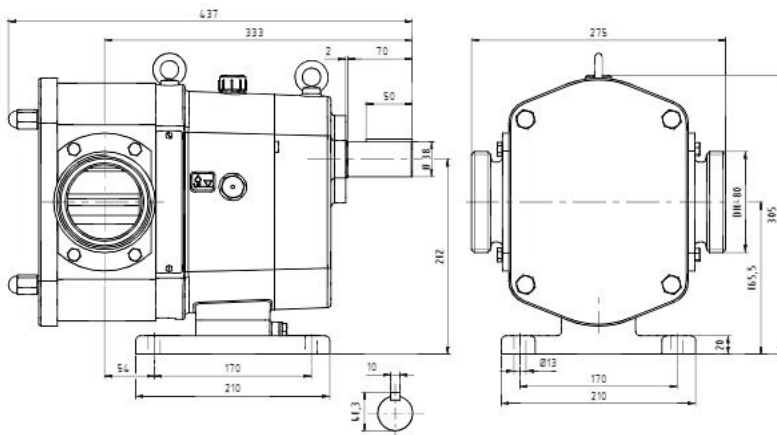

The information is for guidance only. We reserve the right to modify any material or feature without notice in advance. Photos are not binding. For further information, please, consult our web site.

