

AJm

Self-priming Jet Pumps

Application

- It can be used to transfer clean water or other liquids similar to water in physical and chemical properties. It is suitable for lifting water from the well, sprinkling irrigation in garden, pressure boosting of running water, and supporting equipment etc.

Pump

- Cast iron pump body and support under special anti-rust treatment
- Stainless steel impeller
- AISI 304 shaft
- Max. liquid temperature: +40°C
- Max. suction: +9 m

Motor

- C&U bearing
- Motor with copper winding
- Built-in thermal protector for single phase motor
- Insulation class: F
- Protection class: IPX4
- Max. ambient temperature: +40°C

Identification Codes

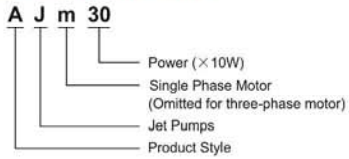

Technical Data

MODEL	POWER		Q (m³/h)												
	Single Phase	Three Phase	0	0.6	0.6	0.9	1.2	1.5	1.8	2.1	2.4	2.8	3.0	3.3	3.6
AJm30	AJ30	0.3 0.4	30	26	23	20	18	16.5	15	13	11				
AJm45	AJ45	0.45 0.6	38	35	31	27	25	22	20	19	16				
AJm60	AJ60	0.6 0.8	43	37	33	30	27	25	23	21	20	18			
AJm75	AJ75	0.75 1.0	46	40	38	36	34	32	30	28	27	25	23	20	
AJm90	AJ90	0.9 1.2	48	44	42	39	37	35	34	31	31	29	28	25	22

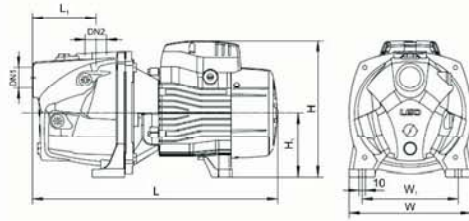

Dimension

Model	DN1	DN2	L (mm)	W (mm)	H (mm)	L (mm)	W (mm)	H (mm)
AJm30	1"	1"	338	160	182	79	125	90
AJm45			338	160	182	79	125	90
AJm60			381	190	212	94	150	100
AJm75			381	190	212	94	150	100
AJm90			381	190	212	94	150	100

Hydraulic Performance Curve

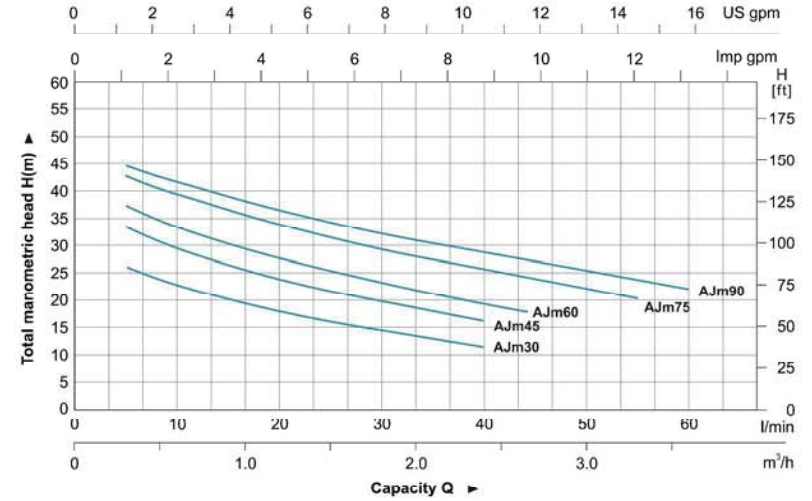

Materials Table

No.	Part	Material
1	Pump body	HT200
2	Venturi tube	PPC
3	Diffuser	PPC
4	Impeller	ABS 304
5	O-ring	NBR
6	Mechanical seal	Carbon/ceramic
7	Bracket cover	HT200
8	Support	ZL102
9	Terminal board	PC
10	Stator	
11	Capacitor box	ABS
12	Capacitor	
13	Rotor	
14	Bearing	
15	End cover	ZL102
16	Fan	PP
17	Blank cover	PP

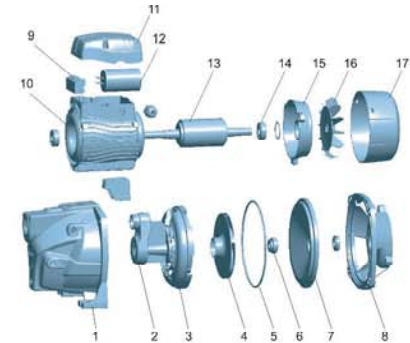

Package Information

Model	GW (Kgs)	L (mm)	W (mm)	H (mm)	Quantity (PCS/20 TEU)
AJm30	8.6	365	185	208	1860
AJm45	9.5				
AJm60	12.9	415	215	238	1215
AJm75	14.2				
AJm90	14.7				